

NOTES :

1. MATERIAL:

- 1.1 HOUSING (A) : HI-TEMPERATURE PLASTIC ,BLACK.
- 1.2 CONTACT (B) : COPPER ALLOY .
- 1.3 MID-PLATE (C) : STAINLESS STEEL.
- 1.4 SHELL (D) : STAINLESS STEEL.

2. FINISH:

- 2.1 CONTACT : Au 1u" ON CONTACT AREA
80u" (Min) NICKEL UNDERPLATING OVERALL & GOLD 1u" ON SOLDER AREA .
- 2.2 SHELL : NICKEL PLATING OVERALL 10u" & GOLD 1u" ON SOLDER AREA .

3. PART NUMBER : YMU0821150

30=CONTACT AREA GOLD PLATED 30u"
15=CONTACT AREA GOLD PLATED 15u"
03=CONTACT AREA GOLD PLATED 3u"

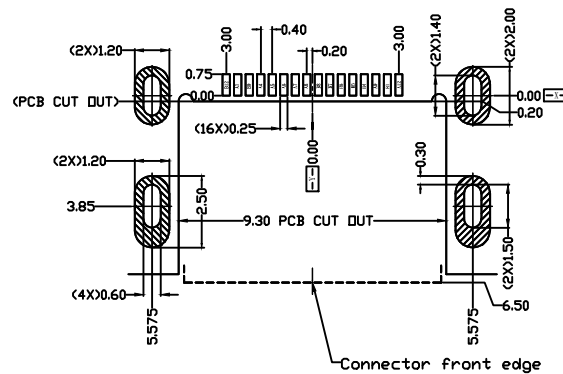
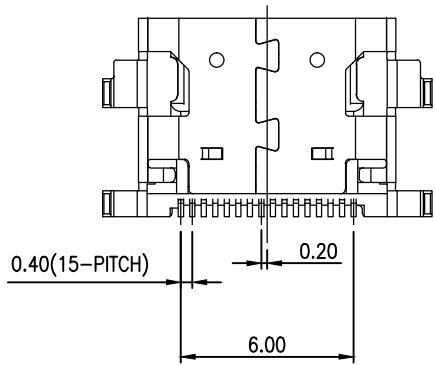
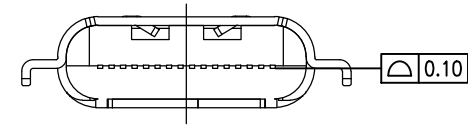
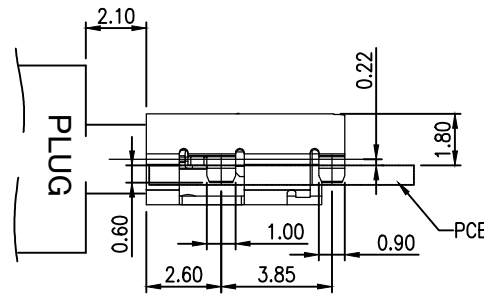
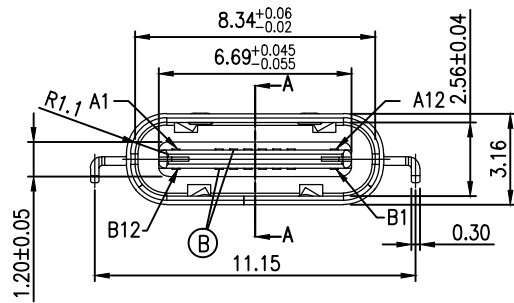

RECOMMENDED P.C.B LAYOUT TOP VIEW
TOLERANCES ± 0.05MM

PIN ASSIGNMENT

A1	A4	A5	A6	A7	A8	A9	A12
GND	VBUS	CC1	D+	D-	RFU1	VBUS	GND
GND	VBUS	RFU2	D-	D+	CC2	VBUS	GND
B12	B9	B8	B7	B6	B5	B4	B1

一般公差 TOLERANCES ANGLES ± 1° X. ± 0.50 .X ± 0.25 .XX ± 0.15 .XXX ± 0.10	A	設計發行	CS.CHEN 2015/12/30	P/NO	YMU0821150	
		TITLE	USB C Type 16 pin for 2.0 (版中)			
	SHEET	1 / 2	App.	Date	Chk.	Date
	SCALE	1 : 2	CS.CHEN 2015/11/05	CS.CHEN 2015/11/05	Bob	2015/11/03
譽盛精密工業股份有限公司 Yue Sheng Exact industrial CO; LTD.						